

TOWN OF PITTSFORD

Building Department

Guidelines & Information

DECKS

What information does the town need to issue a building permit?

- Where will the deck be located (Shown on a copy of the property's survey)?
- Who will be building the deck?
- Does the company or contractor have insurance (If homeowner is building the deck a homeowners exemption form can be used)?
- Do you have any drainage issues where this deck will be located?
- Specifications of the deck:
 1. What size footer will be used, quantity, spacing and how deep.
 2. Will the deck be attached to the house? If so, how will it be attached?
 3. What size, spans and attachments will be used for the beams?
 4. What size, spans and attachments will be used for the joists?
 5. How high will the deck be off the ground?
 6. Will the deck have a railing? If so, what are the specifications for the railing?
 7. Will the deck have stairs? If so, what are the specifications of the stairs? Will they have a railing?

Facts about Decks:

- Decks must be outside the properties setbacks.
- Decks cannot be placed forward of the rear wall of the main structure.
- Decks 30" and more above grade require a railing.
- Note: Decks that are located inside of a properties setback require a variance

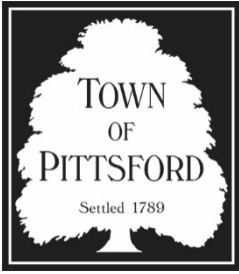

TOWN OF PITTSFORD

Building Department

Guidelines & Information

DECKS

FIGURE R507.2.1(1)
PLACEMENT OF LAG SCREWS AND BOLTS IN LEDGERS

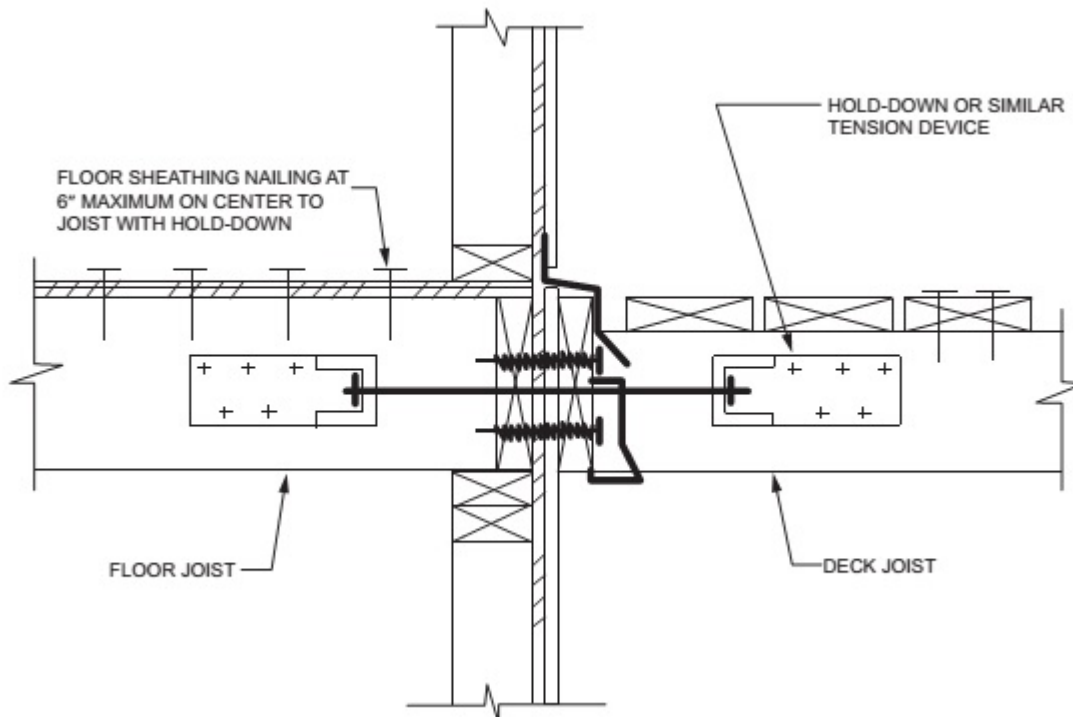
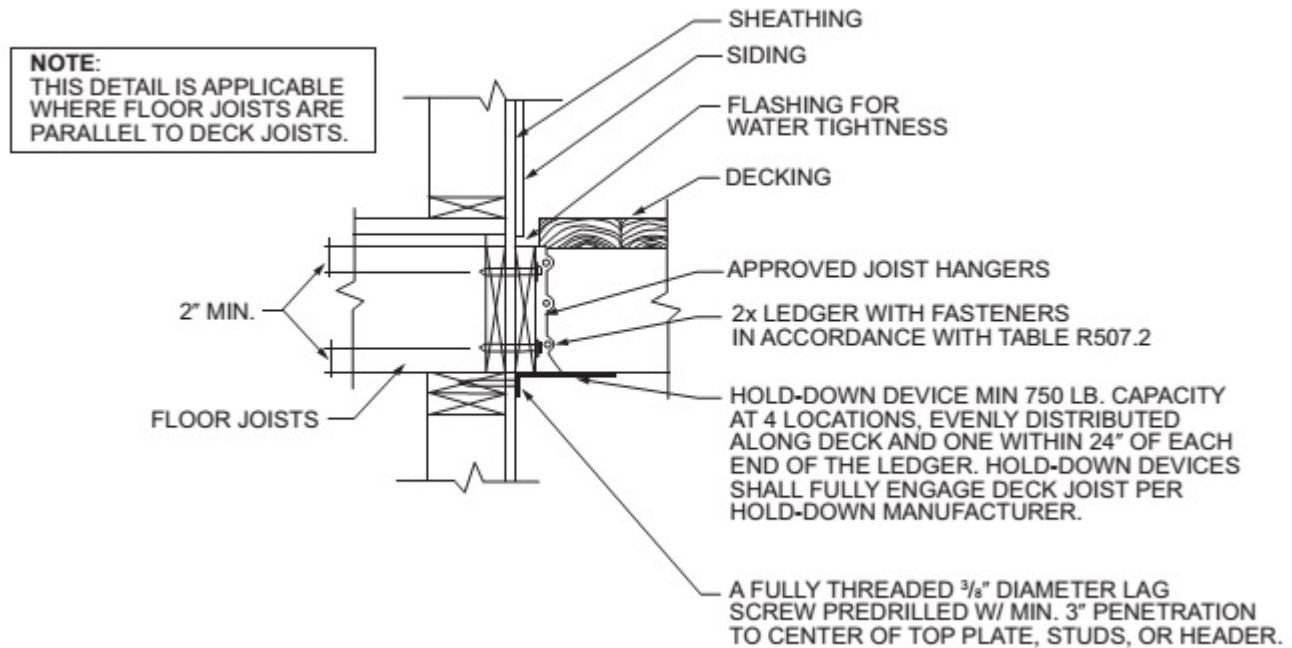

For SI: 1 inch = 25.4 mm.
FIGURE 507.2.3(1)
DECK ATTACHMENT FOR LATERAL LOADS

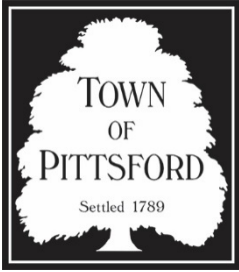

TOWN OF PITTSFORD

Building Department Guidelines & Information DECKS

NOTE:
THIS DETAIL IS APPLICABLE
WHERE FLOOR JOISTS ARE
PARALLEL TO DECK JOISTS.

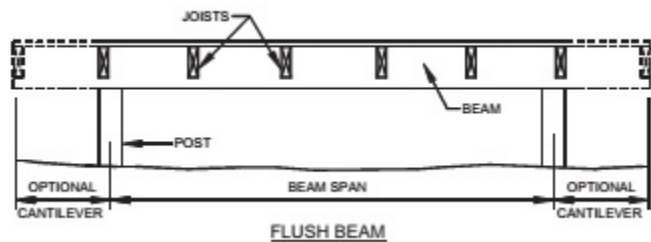
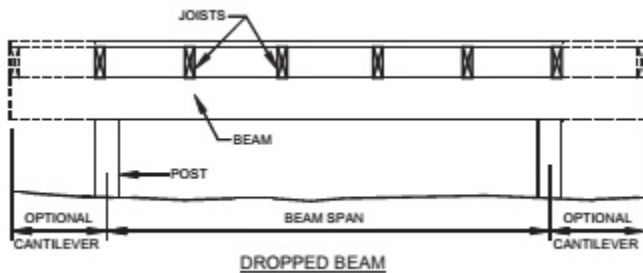
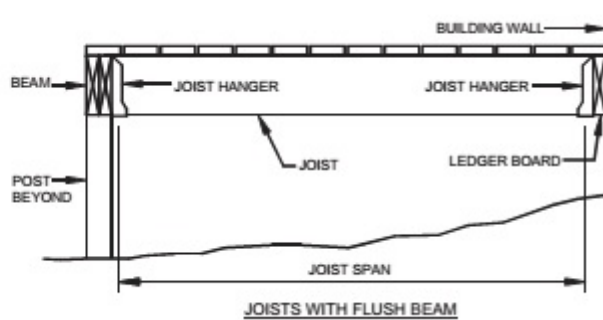
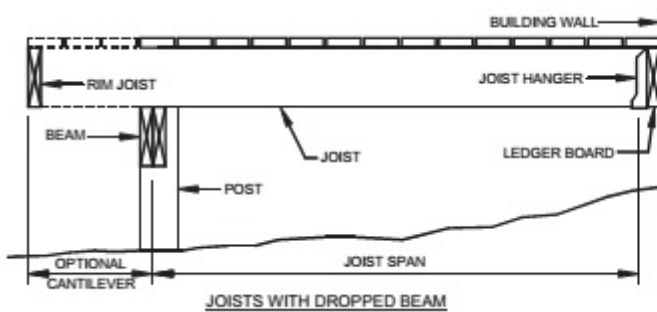
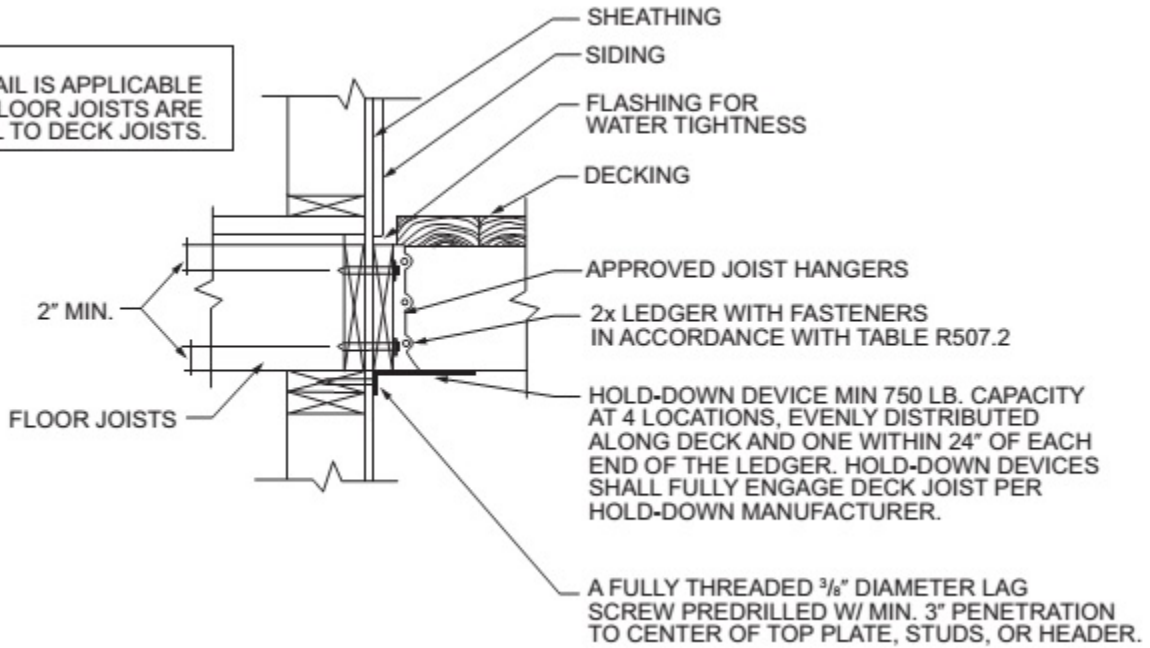

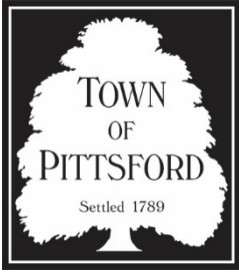

TOWN OF PITTSFORD

Building Department

Guidelines & Information

DECKS

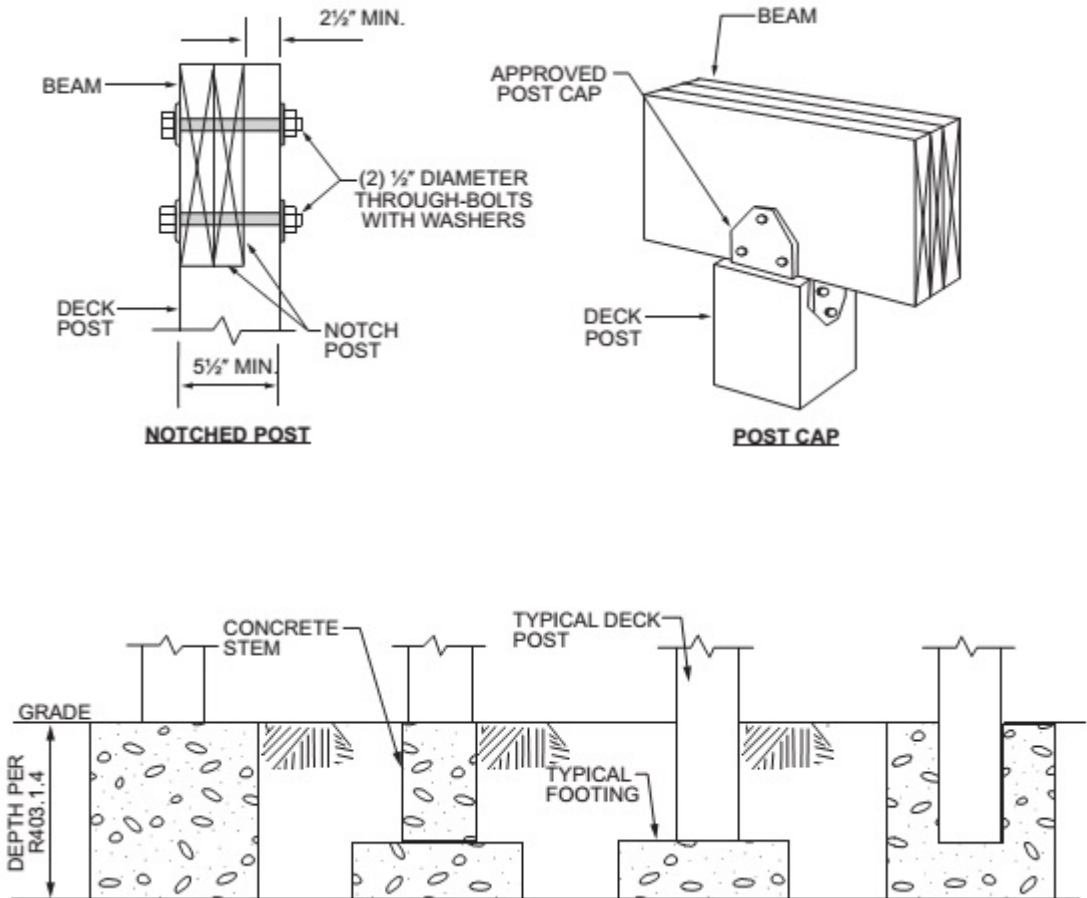

FIGURE R507.8.1